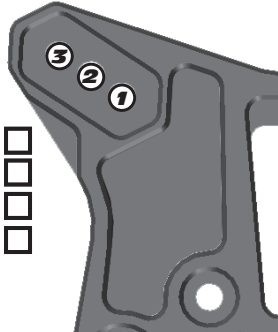

Front Suspension
Steering System:
Swing Rack **Bellcrank Rack**
Anti Roll Bar:

 2.2mm Green
 2.3mm White
 2.4mm Blue
 2.5mm Yellow
Bumpsteer Washers: _____

Camber: _____

Caster: _____

Toe: _____

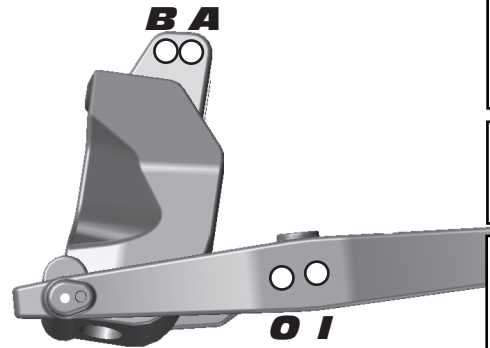
Upper Hinge Pin Bushing
Front # _____
 Up Down
Rear # _____
 Up Down
B-Plate Type

 Low Original
Kickup Bushing A-Plate
_____
 Up Down

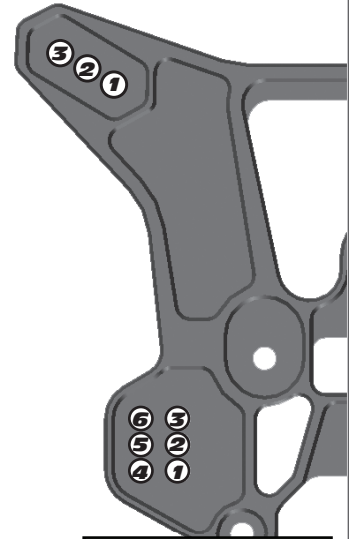
Ride Height: _____

Rear Suspension
Wheelbase:
Long
Medium
Short
Anti Roll Bar:

 2.5mm Green
 2.6mm White
 2.7mm Blue
 2.8mm Yellow
Camber: _____

Toe Bushing D-Plate
_____
 In Out
Squat Bushing C-Plate
_____
 Up Down

Ride Height: _____

Front Shocks
Spring: _____ **Shock Cap:** _____
Shock Fluid: _____ **Length:** _____
Piston: _____ **Rebound:** _____

Rear Shocks
Spring: _____ **Shock Cap:** _____
Shock Fluid: _____ **Length:** _____
Piston: _____ **Rebound:** _____

Chassis Braces / Wheel Hex
Chassis Braces: **Wheel Hex:**
Pivot **Standard**
Molded **Narrow**
Aluminum
Chassis Weight
Weight: _____

Rear Hubs
Rear Hubs:
Standard
CNC FT Alum.
Differentials
Front Diff Fluid: _____
Center Diff Fluid: _____
Rear Diff Fluid: _____

Body / Wing
Body Type: _____
Wing Type: _____
Gap to Tower (MM): _____

Gearing / Clutch
Spur Gear: _____
Clutch Bell: _____
Clutch Shoes: _____
Clutch Spring: _____

Engine
Engine: _____
Restrictor: _____ **Temp:** _____
Muffler: _____
Glow Plug: _____ **Fuel:** _____

Tires
Tire (F/R): _____ / _____
Compound (F/R): _____ / _____
Inserts (F/R): _____ / _____
Wheel (F/R): _____ / _____
Notes: _____

Radio / Servos
Radio: _____ **Brake Bias:** _____
Throttle / Steering Servo: _____ / _____
Throttle / Brake expo: _____ / _____
Steering expo: _____
Dual Rate: _____

Race and Vehicle Comments
Qualify: _____ **Main:** _____ **Finish:** _____ **TQ:** _____
Comments: _____

Track Info
Traction: **High** **Medium** **Low**
Surface: **Smooth** **Bumpy** **Blue Groove**
Soft Dirt **Grass** **Clay** **Wet**
Astroturf **Dusty** **Other:** _____